



DESCRIPTION Non-Contact Liquid Level Bin-Dicator® control is a low cost, floatless, pressure sensitive, diaphragm actuated switch that automates the filling and emptying of containers. The actuated switch requires 5" of head pressure on the riser for actuation. Durable, trouble-free performance is assured because none of the few moving parts come in contact with the liquid. A standard 1" pipe and coupling is all that is required for top of the vessel mounting on almost any size or shape vessel.

FEATURES AND BENEFITS

Actuates Overflow and Low Level Alarms

- Alarms on presence or absence of liquids

Indicates High and/or Low Liquid Levels

- Allows user versatility depending on needs of the application

Optional Side Mounting

- Can be mounted on side of vessel by using a standard 90° aluminum pipe elbow with 1" MPT and a standard aluminum coupling of 1" NPT.

DIMENSIONS

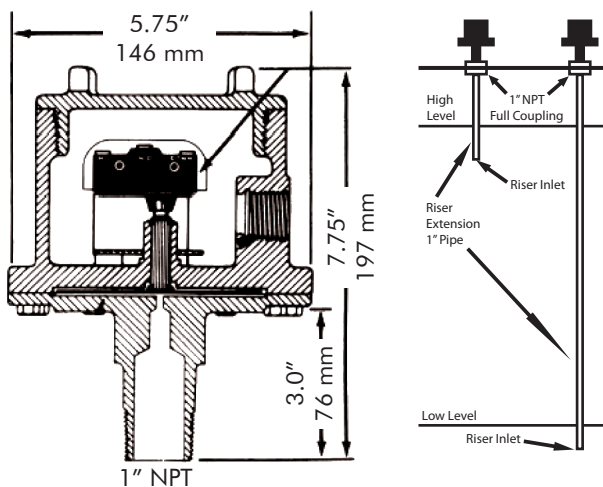

HOW TO ORDER

ENCLOSURE	ORDER NUMBER
Standard	LAG102900 GT-1
Explosion-proof	LAG102901 GTX-1

Advise if maximum temperature at the control housing is in excess of 160° F (71° C). Advise if the air above the liquid is other than atmosphere pressure and if so, to what extent.

SPECIFICATIONS

Housing and Cover	Polyester Coated Aluminum Casting Optional Explosion-Proof
Pressure Chamber	Polyester Coated Aluminum Casting 1" NPT
Diaphragm	Teflon® Faced Neoprene
Switch	Standard SPDT Snap Action Switch (Dry Contact) Rated: 15 amp resistive @ 125, 250 or 480 VAC, 1 H.P. @ 125 VAC, 2 H.P. @ 250 VAC, ½ amp @ 125 VDC, ¼ amp @ 250 VDC
Shipping Weight	7 lbs.
Temperature Rating	32° to +160° F (0° to +71° C)

APPROVALS

GT-1:
UL (US) - General Purpose
CSA - General Purpose

GTX-1:
UL (US) - Hazardous Location for Class 1, Groups C and D; Class II, Groups E, F and G
CSA - Hazardous Location for Class I, Groups C and D; Class II, Groups E, F and G

Note: For high and low level float control, Bindicator® offers Levelite float controllers. Visit www.levelitestore.com for more information.